

2,200-year-old mathematical theory combines with space-age computer design and CNC manufacturing to produce **The Putting Arc®**.
 Now you can feel, see, and learn the Perfect Putting Stroke.

Three Easy Steps to the Perfect Putting Stroke with Your T³ Putting Arc



Learn the “arc type” stroke used by the vast majority of the modern-day touring pros.

- 1 Place Putting Arc 5 to 6 feet from golf hole with this edge aligned 2” left of hole and anchor to green with golf tees.
- 2 Place a ball here with back of ball even with center line & putter face lined up with center line.
- 3 Make a smooth stroke keeping the clubface aligned with the lines on The Putting Arc and the heel in contact.

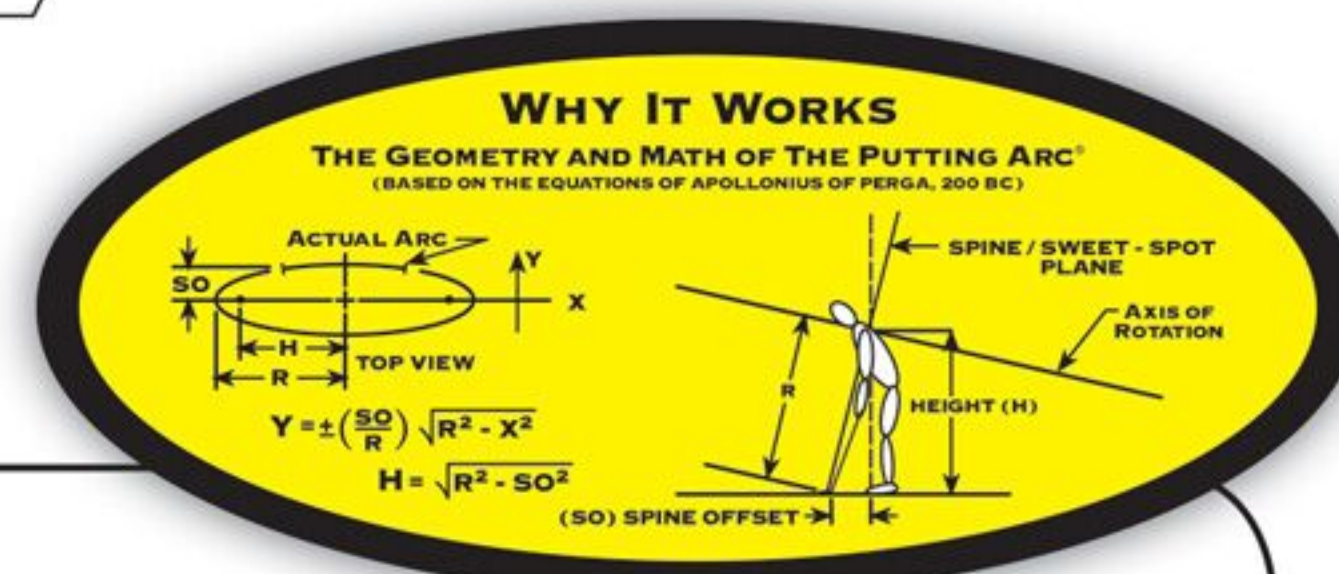
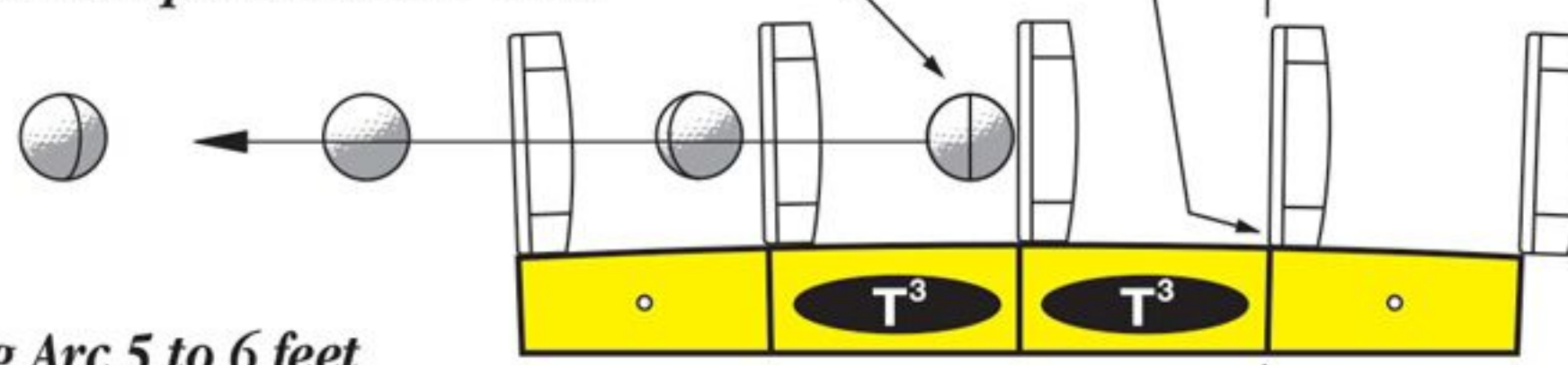

The Putting Arc works because...

1. It is based on a natural body movement which can be quickly learned and repeated. Results can be seen in several days; thousands of repetitions are not required.
2. The clubhead travels in a perfect circle of radius R, on an inclined plane. The projection (or shadow) of this circle on the ground is a curved line called an ellipse, and this is the curve found on **The Putting Arc**.
3. The putter is **always** on plane (the sweet spot/spinal pivot plane). The intersection of this plane with the ground is a straight line, the ball/target line.
4. The clubface is always square to the above plane. It is only square to the ball/target line at the center line on **The Putting Arc**. You are learning an inside to square to inside putting stroke.
5. The lines on the top of **The Putting Arc** show the correct clubface angle throughout the stroke, including a square initial alignment.
This concept is as important as the arc itself, and it is a patented feature of **The Putting Arc**.
6. In this perfect putting stroke, there is only one moving part. The hands, arms, and shoulders rotate as a unit. No manipulation of the hands or arms is required to follow the correct path with a correct clubface. It happens automatically.
7. There are only 2 ways for the putter to travel straight back and straight through...
 - 1) The spinal axis of rotation must be horizontal.
 - 2) You have to manipulate the clubface and clubhead path during the stroke.

Both are unnatural, require many moving parts, and are difficult to repeat consistently. **The Putting Arc can cure the bad habits you have formed trying to make the putter go straight back and straight through down the line, and it will teach you the precision needed to be a consistently great putter.**

Important Note: Do not attempt to move the putter head in a curve! With a correct setup, the heel of the putter will perfectly track along the face of the Putting Arc, and this will happen automatically because the putter is moving on an inclined plane – just like in a full swing.

Over for more info